



FIRE & GAS DETECTION TECHNOLOGIES INC.

User Manual



FlameSpec Flame Simulators

Safety

Warnings:

- Do not try to open, modify or repair the Flame Simulator.
- Inspection and maintenance of this equipment should be performed by suitable trained personnel, in accordance with the applicable code of practice, e.g. EN 60079-17.
- Repair of this equipment should be performed by suitable trained personnel, in accordance with the applicable code of practice, e.g. EN 60079-19. Operation must be in accordance with recognized standards of the appropriate authority in the country concerned.
- Certification of this equipment relies upon use of the following materials in its construction:
Enclosure: Aluminum 6061T6
Window: Sapphire glass
Seals: EPDM
- If the equipment is likely to come into contact with aggressive substances (described below), then it is the responsibility of the user to take suitable precautions (described below) to prevent the equipment from being adversely affected. This ensures that the type of protection provided by the equipment is not compromised.
- Examples of aggressive substances: acidic liquids or gases that may attack metals or solvents, or may affect polymeric materials. Examples of suitable precautions: routine inspections, establishing resistance to specific chemicals from the material's data sheets.

Copyright and Legal Notice

FlameSpec-IR3-HD Flame Simulators User Guide, July 2020

Copyright © Fire & Gas Detection Technologies Inc. All rights reserved.

The owner or authorized user of a valid copy of this manual may reproduce this publication for the purpose of learning to use the specified equipment. No part of this publication may be reproduced or transmitted for commercial purposes, such as selling copies of this publication or for providing paid for support services.

The Fire & Gas Detection Technologies logo is a trademark of Fire & Gas Detection Technologies Inc., registered in the U.S. and other countries.

Every effort has been made to ensure that the information in this manual is accurate. However, Fire & Gas Detection Technologies Inc. is not responsible for any inaccuracy or omission in this document. The information in this document is subject to change without notice.

Legal Notice

Hardware, software or documentation is forbidden to be reproduced, transmitted, transcribed, stored in a retrieval system or translated into any language or computer language, in any form or by any means.

While great efforts have been made to assure the accuracy and clarity of this document, FIRE & GAS DETECTION TECHNOLOGIES INC. assumes no liability resulting from any omissions in this document, or from misuse of the information obtained herein. The information in this document has been carefully checked and is believed to be entirely reliable with all of the necessary information included.

FIRE & GAS DETECTION TECHNOLOGIES INC. reserves the right to make changes to any products described herein to improve reliability, function, or design, and reserves the right to revise this document and make changes from time to time in content hereof with no obligation to notify any persons of revisions or changes. FIRE & GAS DETECTION TECHNOLOGIES INC does not assume any liability arising out of the application or any use of any product or circuit described herein; neither does it convey license under its patent rights or the rights of others.

Table of Contents

Safety	ii
Copyright and Legal Notice	iii
1 Introduction	1
2 Operation	2
2.1 Flame simulator activation	2
3 LED Status, Faults & Warnings	3
4 Servicing/Maintenance	4
4.1 Simulator charging	4
4.2 Battery replacement	4
5 Specifications	5
5.1 Mechanical	5
5.2 Electrical	5
5.3 Environmental	5
5.4 Approvals	5
5.5 Physical Dimensions	6
6 Ordering Information	7
7 Warranty	8

Table of Figures

Figure 1 - Flame Simulator Kit Layout.....	1
Figure 3 - Dimensions (in mm).....	6

1 Introduction

This manual describes the FlameSpec Flame Simulators that are part of the FlameSpec family of products. Three different models of simulator are available for testing each type of FlameSpec Detector (IR3, IR3-H2 and UV-IR). FlameSpec Flame Simulators provide fast and convenient means for periodic flame detector and end-to-end system verification in the field without removing the detector from the location or hazardous area. Maintenance costs are therefore reduced.

FlameSpec Flame Simulators emit either IR or UV - IR radiation (according to the model) in a special electromagnetic radiation pattern which simulates a fire to the detectors. The simulators are lightweight, easy to use, with testing distances of up to 23 ft. (7m). The IR3 version is capable of more than 1000 activations between battery charging. FlameSpec Flame Simulators are ATEX approved for use in hazardous Zone 1, Zone 2, Zone 11, Zone 22 areas.

Each simulator kit contains a carrying case, simulator, carrying strap, battery charger, user manual, Allen key and a tool for removing the simulator rear cover.



FIGURE 1 - FLAME SIMULATOR KIT LAYOUT

- | | |
|---------------------|--------------------|
| 1. Strap Range Tool | 4. Battery Charger |
| 2. Flame simulator | 5. Adaptors |
| 3. Carrying Strap | 6. Carrying Case |

2 Operation

2.1 Flame simulator activation

⚠ Warnings:

- **Testing using a flame simulator to simulate a fire to the detector may activate alarms or extinguishing systems in the area unless disabled/inhibited/bypassed.**
- **All tests should be coordinated, and if needed, disconnect/disable the alarm and/or the extinguishing systems before the test, and reconnect after the test.**

Flame Simulator Key Components



4. Push Button

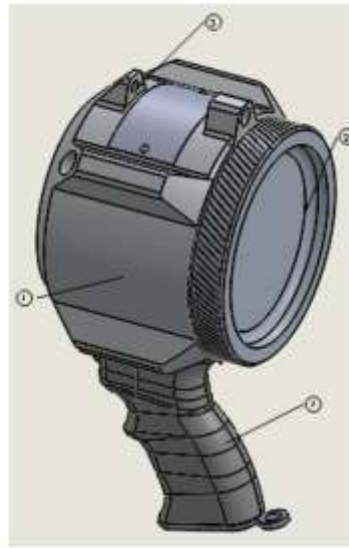

1. Electronic Chamber
2. Battery Cover
3. Aiming Sights
7. Handle

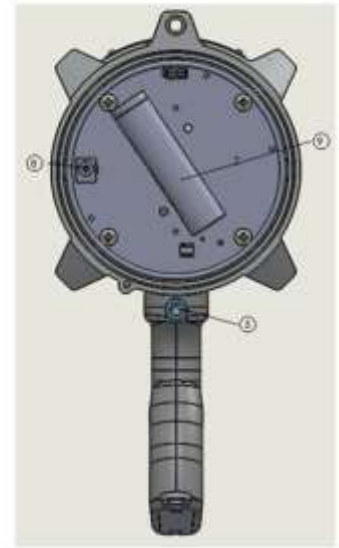

5. LED status Indicator
8. Power Supply Input
9. Battery

1. Remove simulator from the case and verify the simulator battery is charged.
2. Ensure use of the correct flame simulator model according to the detector type.
3. Make sure you are testing within the specified distance, according to the detector sensitivity. See Table 1 below.
4. Point the flame simulator at center of detector by aligning the front and back aiming sights located on the top of the simulator (3).
5. The simulator should be aimed within $\pm 30^\circ$ from the horizontal and vertical center line axis of the detector.
6. Press the push button (4) to activate, notice the flashing green LED. Wait for the flame detector to enter into alarm (typically 10 seconds). Go to the next detector and repeat the test.

Note: factory default settings for Detectors sensitivity is Medium

Simulator Kit		FLS-FSIM-IR3-KIT	FLS-FSIM-IR3-H2-KIT	FLS-FSIM-UV-IR-KIT
Use with Detector Model		FLS-IR3-HD	FLS-IR3-H2-HD	FLS-UV-IR-HD
		FLS-IR3	FLS-IR3-H2	FLS-UV-IR
		ft. (m)	ft. (m)	ft. (m)
Detector Sensitivity Setting	Extreme	23.0 (7.0)	23.0 (7.0)	21.3 (6.5)
	High	16.0 (5.0)	16.0 (5.0)	16.0 (5.0)
	Medium	10.0 (3.0)	10.0 (3.0)	13.0 (4.0)
	Low	3.3 (1.0)	3.3 (1.0)	3.3 (1.0)

3 LED Status, Faults & Warnings

The flame simulator has a tri-color LED which indicates the operational status of the simulator as described in the table below.

LED Status	Indication	Action
Flashing green	Normal operation	Ready for use
Flashing orange	Battery at medium capacity	Charge battery for 3 hours
Solid orange	Unit is in fail mode	Return for repair
Solid red	No power	Recharge/replace the battery
Off	No power	Recharge/replace the battery
Flashing green LED but simulator fails to activate detector alarm	Detector is unable to read the signal from the Simulator	<ol style="list-style-type: none"> 1. Check you are within the specified distance from the detector according to the detector's sensitivity setting. 2. Check detector is powered and operational. 3. Check simulator window is clean. 4. Check detector window is clean, and not in fault or indicating 2mA output to the panel indicating a dirty window. <p>Note: Any alarm delay set in the detector will require the simulator to be aimed at the detector for that period plus up to 10 more seconds.</p>

4 Servicing/Maintenance

Warnings:

- ***Do not try to open, modify or repair the Flame Simulator.***
- ***Repair, inspection or maintenance of this equipment should be performed by suitable trained personnel, in accordance with the applicable code of practice, e.g. EN 60079-19. Operation must be in accordance with recognized standards of the appropriate authority in the country concerned.***
- ***Charge battery in a safe area– Battery chamber should only be opened in a non-hazardous location.***

1. Periodically, the flame simulators front window should be cleaned using a soft cloth, water and a mild detergent. Clean and dry window.
2. Always make sure the flame simulator battery is fully charged prior to use.
3. To maintain the battery life, it should be fully charged at least once in a 3-month period.
4. Replace battery only with part number FLS-FSIM-BATT

4.1 Simulator charging

 Charge battery in a safe area – Battery chamber should only be opened in a non-hazardous location.

1. Release the locking screw using the Allen key
2. Using strap wrench tool to remove the back-battery cover (2) of simulator by unscrewing
3. Connect supplied charger to charging jack (8) and connect charger to power supply, 110-220VAC.
4. Allow to charge for at least 3 hours until the green LED on the charger is seen
5. Disconnect charger, close back-battery cover (2) and tighten using the removal tool.
6. Close the locking screw using the Allen key.

4.2 Battery replacement

 Battery replacement in a safe area– Battery chamber should only be opened in a non-hazardous location.

1. Release the locking screw using the Allen key
2. Using strap wrench tool to remove the back-battery cover (2) of simulator by unscrewing.
3. Disconnect the battery connector from the PCB
4. Remove the Battery by pulling it out from the holder
5. Put a new Battery in place and connect the connector

6. Connect supplied charger to charging jack (8) and connect charger to power supply, 110-220VAC.
7. Allow to charge for at least 3 hours.
8. Disconnect charger, close back-battery cover (2) and tighten using the removal tool.
9. Close the locking screw using the Allen key.

5 Specifications

5.1 Mechanical

Size	3.9 x 3.9 x 7.8 inch (100 x 100 x 200mm)
Weight	3.96lbs. (1.8Kg)
Enclosure	Painted Aluminum LM25
Ingress protection	IP65 (NEMA 4X)

5.2 Electrical

Power	Li-ion 3.7V
Maximum current	0.5A (IR models) / 0.7A (UV-IR model)
Battery capacity	> 3000mAh
Charging time	3 Hours

5.3 Environmental.

Temperature	
Storage:	-4°F (-20°C) to +122°F (+50°C)
Operation:	-4°F (-20°C) to +122°F (+50°C)
Humidity:	up to 99%, non-condensing

5.4 Approvals

ATEX:
 Ex II 2 G D
 Ex db ib op is IIC T6 Gb
 Ex tb ib op is IIIC T85°C Db
 -20°C to +50°C / -4°F to +122°F

5.5 Physical Dimensions.

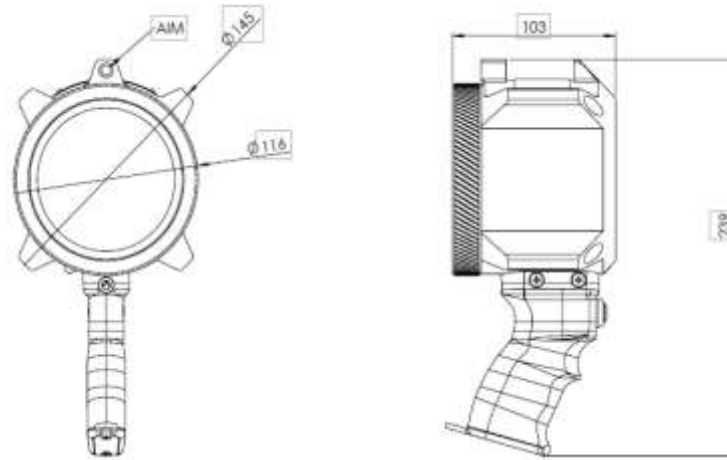

FIGURE 2 - DIMENSIONS (IN MM)

6 Ordering Information

Part Number	Description
Simulator Kits	
FLS-FSIM-IR3-KIT	IR3 FlameSpec flame simulator kit including carry case, simulator, carrying strap, charger and manual
FLS-FSIM-UV-IR-KIT	UV-IR FlameSpec flame simulator kit including carry case, simulator, carrying strap, charger and manual
FLS-FSIM-IR3-H2-KIT	IR3 Hydrogen FlameSpec flame simulator kit including carry case, simulator, carrying strap, charger and manual
Accessories & Spares	
FLS-FSIM-CASE	Carrying case
FLS-FSIM-STRAP	Carrying strap
FLS-FSIM-TOOL	Cover removal tool
FLS-FSIM-ALLEN	Allen Key
FLS-FSIM-CHRGR	Power supply and charger
FLS-FSIM-BATT	Replacement Battery

7 Warranty

FIRE & GAS DETECTION TECHNOLOGIES INC. agrees to extend to Purchaser/Distributor a warranty on the FIRE & GAS DETECTION TECHNOLOGIES INC. supplied components of the FlameSpec products. FIRE & GAS DETECTION TECHNOLOGIES INC. warrants to Purchaser/Distributor that the products are free from defects in materials and workmanship for a period of three (3) years, commencing with the date of delivery to Purchaser/Distributor. FIRE & GAS DETECTION TECHNOLOGIES INC. expressly excludes damage incurred in transit from the factory or other damage due to abuse, misuse, improper installation, lack of maintenance or "Act of God" which are above and beyond its control. FIRE & GAS DETECTION TECHNOLOGIES INC. will, upon receipt of any defective product, transportation prepaid, repair or replace it at its sole discretion if found to have been defective when shipped. Said repair or replacement is FIRE & GAS DETECTION TECHNOLOGIES INC. sole liability under this warranty and FIRE & GAS DETECTION TECHNOLOGIES INC. liability shall be limited to repair or replacement of the component found defective and shall not include any liability for consequential or other damages. The customer is responsible for all freight charges and taxes due on shipments both ways. This warranty is exclusive of all other warranties express or implied.