



User Manual



Gas Detector

Alpa EcoTerm XT

Product code: PW-100-NG



Reliable and Innovative **Gas Detection & Safety Systems**

We design, manufacture, implement and support:
Systems for Monitoring, Detection and Reduction of gas hazards

We invite you to familiarize yourself with our offer on **www.atestgaz.pl**

Atest Gaz A. M. Pachole sp. j.
ul. Spokojna 3, 44-109 Gliwice
Poland

tel.: +48 32 238 87 94
fax: +48 32 234 92 71
e-mail: contact@atestgaz.pl

www.atestgaz.pl

Remarks and reservations

- Read and understand this manual prior to connection and operation of the device. Keep the User Manual with the device for future reference.
- The manufacturer shall not be held responsible for any errors, damage or defects caused by improper selection of suitable devices or cables, errors in installation of equipment or any misuse due to failure to understand the document content.
- Unauthorised repairs and modifications of the device are not allowed. The manufacturer shall discard any responsibility for consequences of such actions.
- Exposure of the device to the impact of excessive mechanical, electric or environmental factors may lead to damage of the device.
- Operation of damaged or incomplete devices is not allowed.
- Engineering of a gas safety system for any specific facilities to be safeguarded may need consideration of other requirements during the entire lifetime of the product.
- Use of unauthorized spare parts different from the ones listed in Table 9 is strictly forbidden.

How to use this manual?

- Important fragments of the text are highlighted in the following way:



Pay extreme attention to information provided in such framed boxes.

- This User Manual consists of a main text and attached appendices. The appendices are independent documents and can be used separately from this Manual. Page numbering of appendices starts anew with no relationship to page numbering of the main document and appendices may have their own tables of contents. In the right bottom corner of each page you can find the name (symbol) of any document included into the User Manual package with its revision (issue) number.

Table of contents

1 Preliminary information.....	5
1.1 Purpose.....	5
1.2 Description of operation.....	5
2 Safety.....	7
3 Description of the construction.....	9
4 Input-output interfaces.....	9
4.1 Electric interfaces.....	9
5 User interface.....	9
6 System architectures.....	11
6.1 Star system.....	11
6.2 Open alarm loop.....	12
6.3 Closed alarm loop.....	12
6.4 Other architectures.....	13
7 Device configuration.....	13
7.1 Detector location.....	13
7.2 Adjustment of the LED indicator intensity.....	14
8 Diagnostics of electrical connections – searching for connection errors.....	15
9 Life cycle.....	15
9.1 Transport.....	15
9.2 Set-up.....	15
9.3 Start-up.....	21
9.4 Periodical operations.....	22
9.5 Utilization.....	23
10 Technical specification.....	24
11 List of consumables.....	25
12 List of accessories.....	25
13 Product marking.....	25
14 Appendices.....	25

List of Tables

Table 1: Priorities of the Alpa EcoTerm XT Gas Detector.....	6
Table 2: Electric interface description.....	9
Table 3: Indication of operating conditions.....	10
Table 4: Signalling archive status (SW3 in position 1).....	11
Table 5: Signalling archive status (SW3 in position 2).....	11
Table 6: Device configuration.....	14
Table 7: Reasons for failure signalling.....	15
Table 8: Technical specification.....	24
Table 9: List of consumable parts.....	25
Table 10: List of accessories.....	25
Table 11: Method of product's marking.....	25

List of Figures

Figure 1: The construction of the device and its dimensions.....	9
Figure 2: Connection with the Alpa MOD LED8 control unit into a star-shaped system.....	12
Figure 3: Connection with the Alpa MOD LED1 control unit into an open bus system.....	12
Figure 4: Connection with the Alpa MOD LED1 control unit into a closed bus system.....	13
Figure 5: Connecting into two open bus systems servicing two zones.....	13
Figure 6: Settings of the configuration switch.....	14
Figure 7: Example connection of cables to the device.....	17
Figure 8: Connection into the star system.....	18
Figure 9: Open bus system.....	19
Figure 10: Closed alarm loop.....	20

1 Preliminary information

1.1 Purpose

Alpa EcoTerm XT is a 3-threshold gas detector designed to detect the presence of hazardous concentrations of natural gas in the surrounding atmosphere, primarily in facilities heated with natural gas (e.g. boiler rooms or industrial halls heated with heaters).











The Alpa EcoTerm XT Gas Detector is not designed for installation in areas with potentially explosive atmospheres.

A catalytic sensor was used as an element detecting the presence of a hazardous gas. This solution is characterized by a high resistance to the change of environmental conditions, such as temperature, humidity, pressure. The Alpa EcoTerm XT Gas Detector is also characterized by high resistance to the presence of disturbing factors which eliminates generation of false alarms.

More details on catalytic sensors can be found in Appendix [2].

Basic operational features include:

-  safe, low voltage electric circuits,
-  adjustable intensity of the detector warning light to local conditions (height of a facility, layout of detectors)
-  easy installation,
-  possibility to arrange the components as a 'bus layout' or a 'star layout',
-  quick calibration of the detector by simple replacement of the MniPel Head (reduction of the calibration time),
-  three alarm thresholds,
-  indication of detector failures or interruption of the monitoring loop,
-  log of events to enable viewing historical events associated with exceeding of alarm thresholds or detector failures,
-  long term operation with steady parameters.

These features, at an extremely attractive price, make Alpa EcoTerm XT Gas Detector an ideal solution for low cost applications, e.g. in public construction.

1.2 Description of operation

The Alpa EcoTerm XT Gas Detector is one of the elements of the gas detection system. It performs cyclical measurements of gas concentration in the air. Information about exceeding a certain threshold is transmitted using the controls located on the bottom side part of the housing (see Figure 1) and output current signal. In addition, if it works in an alarm loop system (see Section 6.3), at its input (via an XT T- connector) a current signal can be passed from the next detector. This signal is compared with the local value and a signal corresponding to a status of a higher priority is transmitted to the output (see Table 1).

Priorities	State of operation
1 (highest)	Exceeded alarm threshold
2	Exceeded warning threshold 2
3	Exceeded warning threshold 1
4	Damage to the detector, bus or information on an incorrect setting of the configuration switch
5 (lowest)	Correct operation of the detector
	Warm-up

Table 1: Priorities of the Alpa EcoTerm XT Gas Detector





The type of gas, the thresholds and the corresponding current value for a specific detector should be checked in the calibration certificate.

In the course of its work, the detector makes continuous measurements of gas concentrations in the environment, and carries out regular tests of the sensor. Depending on the outcome of these actions, it distinguishes between the states described in the following sections.

1.2.1 Operation

It is a condition in which the detector works properly and conducts measurements. The value of the measured concentration of gas is below the thresholds and no irregularities were detected in the operation. The detector does not require special attention of the user, except for:

-  possibly frequent readout, preferably daily,
-  systematic ordering of inspections (see Subsection 9.4.3).

In that mode the detector can present history of its operation, i.e. exceeding of warning and/or alarm thresholds as well as failures (if such events took place during the most recent 72 hours).

1.2.2 Warning 1 (threshold 1) / Warning 2 (threshold 2)

It is a condition that occurs when a low gas concentration is detected that requires informing the user.

Actions to be taken:

-  check the cause, which can be e.g.
 - a leak at the facility,
 - interruption of the detector operation by other substances (e.g. a high-concentration solvent or fuel vapours) – the substances should be removed from the supervised premises,
 - shift of the detector characteristics. Over time, the detectors tend to zero drift. Therefore, if they are not calibrated periodically, it may happen that the warning threshold will move to the level of clean air. The cause of this should be suspected in a situation when competent services checked the lack of gas leakage in the facility with a special device, and no presence of interfering substances was found.

1.2.3 Alarm (threshold 3)

This state occurs when the gas concentration exceeds the alarm threshold (3rd threshold).

Actions to be taken:

- remove bystanders from the danger zone,
- as far as possible, allow the airing of the endangered rooms – by opening windows and doors (if the control unit does not automatically switch on the ventilation).

1.2.4 Failure

Simultaneously with the process of gas concentration measurement, the detector performs a number of diagnostic measurements in order to validate its own work and the system operation.

The internal failures signalled by the detector concern problems with the sensor.

The system failures signalled by the detector may concern:

- breakage of the bus,
- abnormal values of currents flowing into the detector,
- incorrect settings of the configuration switch,

1.2.5 Warm – up

After powering the detector, the parameters of the sensor stabilize for some time. In this state, the detector does not conduct measurements. This state takes about 1 minute, after which the sensor starts to operate normally.

2 Safety



Do not allow cutting or damaging the insulation of the wires connecting the system.



Do not install a gas detector in places exposed to direct sunlight and water.



In the case of damage, shut down the detector, secure the connection cables, and conduct the service.



All activities related to connecting detectors, signallers and other system components must be carried out while Control Unit's power supply is off.



Although switching power supply of the Gas Detection System off, there is a possibility that a dangerous voltage can exist on the terminals of the Control Unit. It can originate from another system like for an example ventilation system that uses one of the output pins of Control Unit.



When performing repair, building and maintenance works, secure the device in a proper way.



Before painting the walls, make sure the device is secured.



Before painting the floors, make sure the device is secured.



Before using silicones or silicon-containing materials (paints, glues, sealing etc.), make sure the device is secured.



Silicon-based materials irreversibly damage the gas sensor incorporated into the detector. Other incompatible substances are listed in the Attachment [2].

3 Description of the construction

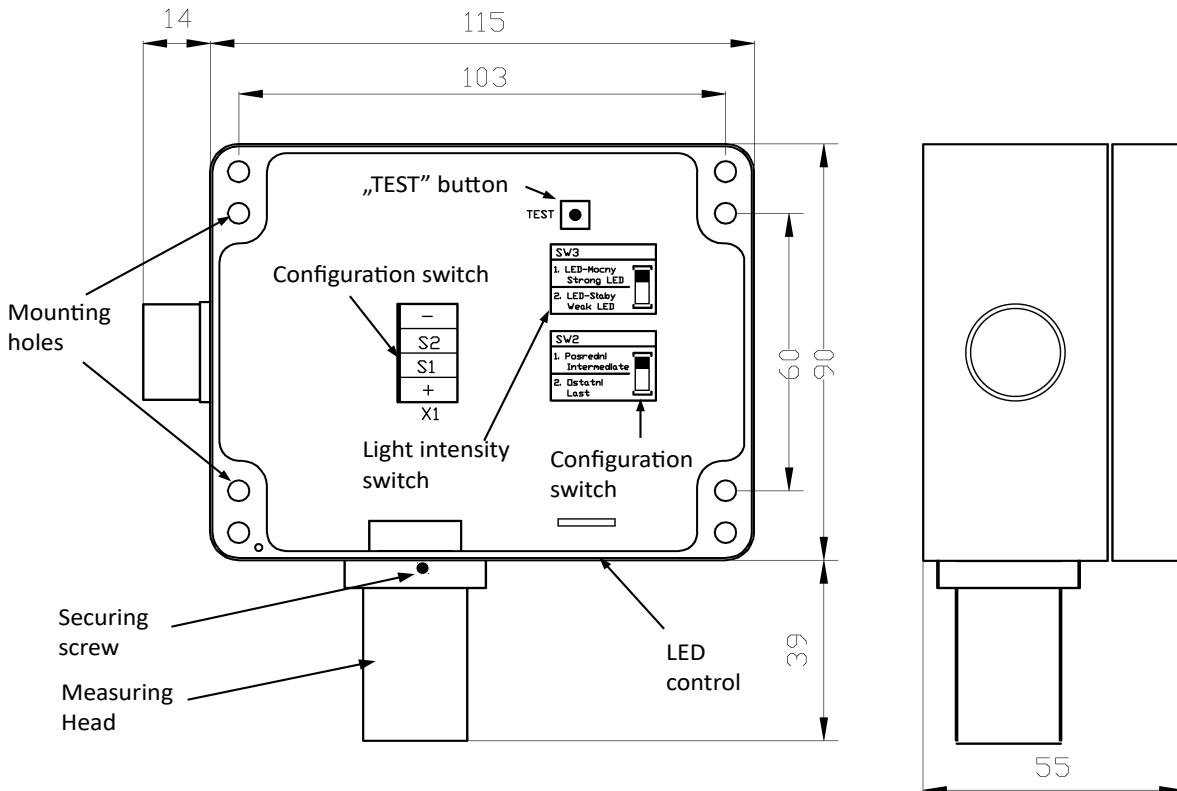

Figure 1: The construction of the device and its dimensions

4 Input-output interfaces

4.1 Electric interfaces

The appearance of the terminal strip is shown in Figure 1.

Port name	Pin	Opis
X1		Port of the detector bus / T-connector XT / control unit. Parameters – see Section 10
	-	Negative power pole
	S2	Signal line S2
	S1	Signal line S1
	+	Positive supply pole

Table 2: Electric interface description

5 User interface

The detectors have a function of signalling statuses by means of one LED indicator located on the bottom of the housing (see Figure 1).

The indicator lamps presents:

- current status of the detector,

 stored (historical) events affecting status of the detector, i.e. warning and/or alarms reported by the detector as well as detector failures.

The detector also makes it possible to adjust intensity of LED indicator light designed to present correct operation of the detector (see details in Section 7.2).

Table 3 summarizes all signals that indicate the current status of the detector.





Status of indicator LEDs	Status of the detector operation	Status of interconnections check	Meaning
	Warm-up	-	Gas detector activation
	OK	OK	The detector works properly, gas concentration below the determined thresholds
	Warning 1	OK	Exceeded warning threshold 1
	Warning 2	OK	Exceeded warning threshold 2
	Alarm	OK	Exceeded alarm threshold
	Failure	OK	Failure – detector damage
	OK	Failure	The detector works properly, gas concentration below the determined thresholds The detector also indicates an interruption of electric interconnections or another detector failure, incorrect values of electric current (see details is Section 8)
	Warning 1	Failure	Exceeded warning threshold 1 The detector also indicates an interruption of electric interconnections or another detector failure, incorrect values of electric current (see details is Section 8)
	Warning 2	Failure	Exceeded warning threshold 2 The detector also indicates an interruption of electric interconnections or another detector failure, incorrect values of electric current (see details is Section 8)
	Alarm	Failure	Exceeded alarm threshold The detector also indicates an interruption of electric interconnections or another detector failure, incorrect values of electric current (see details is Section 8)
	Failure	Failure	Detector damage The detector also indicates an interruption of electric interconnections or another detector failure, incorrect values of electric current (see details is Section 8)

Table 3: Indication of operating conditions

- 1 G – green, Y – yellow, R – red.
- 2 Light intensity switch SW3 in position 2 – LED – Low.

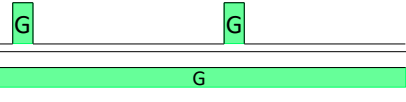
When the detector works properly it is possible to view historical events associated with exceeding of warning /alarm thresholds or detector failures.

The way how historical events are indicated by means of front panel LEDs for the light intensity switch SW3 set to position 1 (LED – strong) is explained in Table 5.

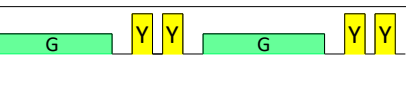
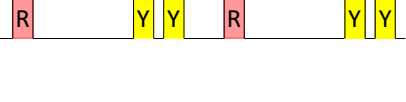
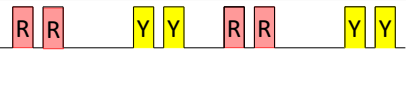
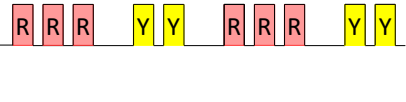
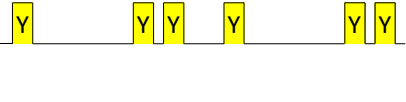



State of the indicators	Stored state
	Warning 1
	Warning 2
	Alarm
	Failure

Table 4: Signalling archive status (SW3 in position 1)

The way how historical events are indicated by means of front panel LEDs for the light intensity switch SW3 set to position 2 (LED – weak) is explained in Table 5.

State of the indicators	Stored state
	Warning 1
	Warning 2
	Alarm
	Failure



Table 5: Signalling archive status (SW3 in position 2)

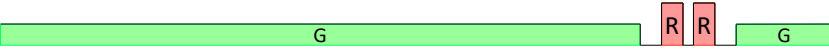
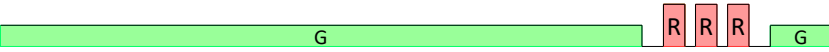
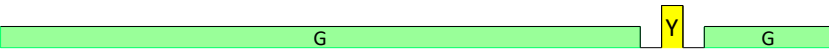

The detector memory is automatically erased after 72 from the moment when the recorded event takes place or after the power voltage for the detector is off during at least 10 seconds.

6 System architectures

Detectors can be connected in two ways:

-  star system (traditional) or,
-  into a serial "bus" arrangement (alarm loop) – open or closed.

6.1 Star system

In the conventional system each detector is individually connected to the control unit. This solution requires the input of a large number of wires to the control unit, which can be a serious impediment to the assembly – particularly in large buildings, and the increase in wiring costs.

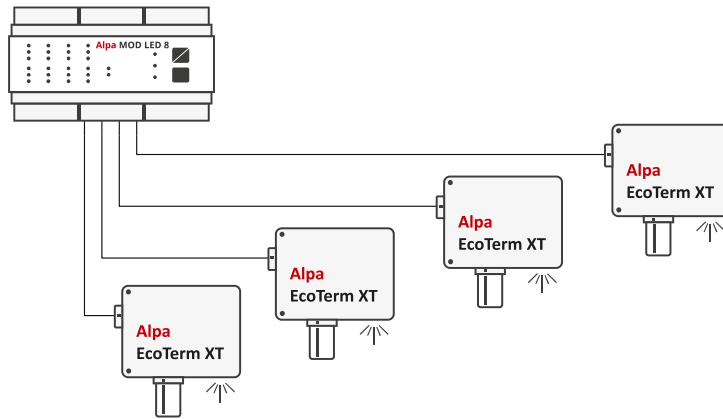

Figure 2: Connection with the Alpa MOD LED8 control unit into a star-shaped system

6.2 Open alarm loop

In this arrangement, the detector are connected in series to the bus line via the XT T-shaped connector. An advantage of this solution is significant facilitation of the system installation and reducing the wiring costs.

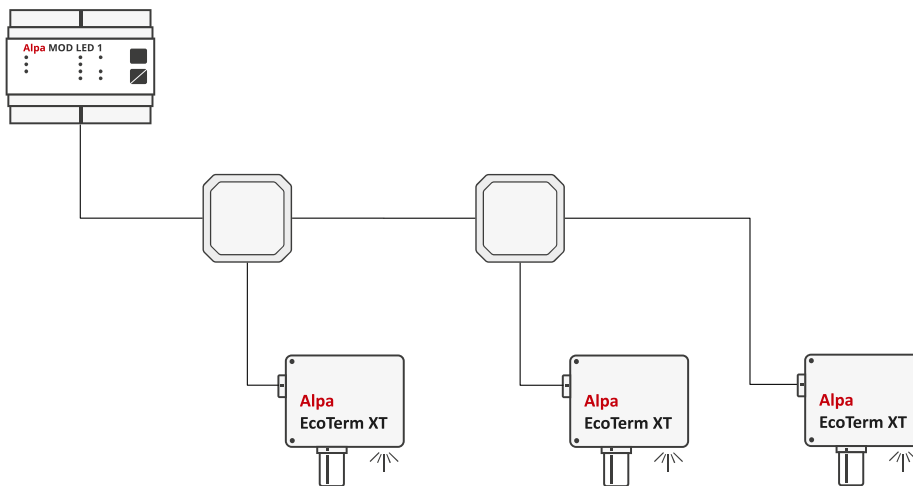

Figure 3: Connection with the Alpa MOD LED1 control unit into an open bus system

6.3 Closed alarm loop

This system is different from the previous one in terms of connection of the end of the supply and signal line back to the control unit of the loop equipped with a test output (e.g. Alpa MOD LED1 Control Unit). In this way, it is possible to improve the power supply conditions of the sensor and resistance to damage. In this system it is also possible to check the loop continuity and the regularity of the system operation by enforcing the alarm at the "test output of the loop" in the control unit. This makes it easier to carry out periodic checks of the system.

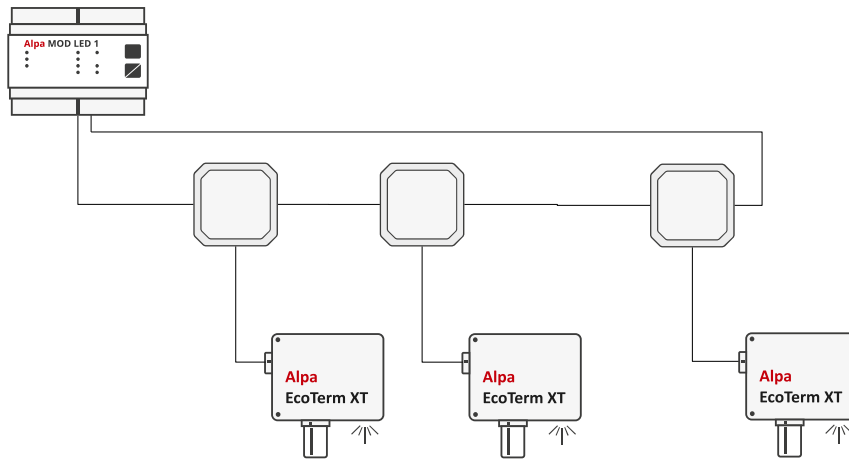

Figure 4: Connection with the Alpa MOD LED1 control unit into a closed bus system

6.4 Other architectures

It is also possible to use modification of the described architectures. For example, by connecting several bus systems to single inputs of the control unit, it is possible to create a system composed of several independent zones using only one control unit. However, it is necessary to remember that it may be possible to supply the bus systems from additional power sources that will provide adequate current capacity of the system.

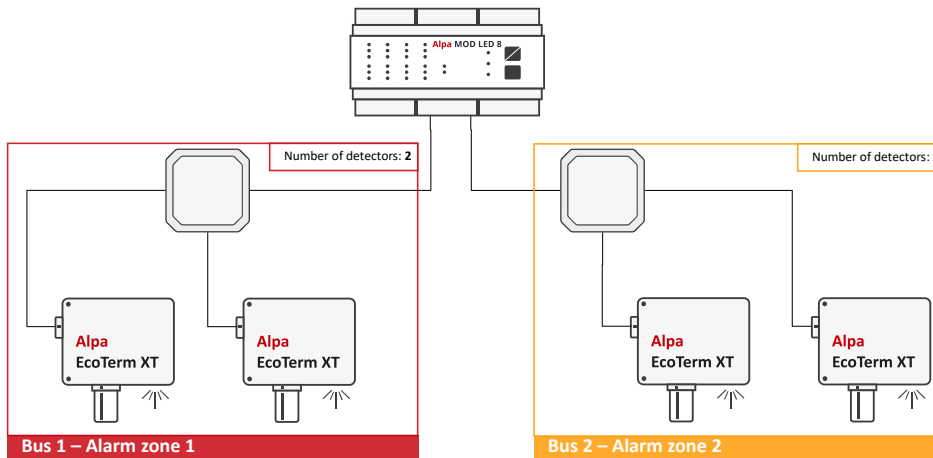

Figure 5: Connecting into two open bus systems servicing two zones

7 Device configuration

7.1 Detector location

For correct operation of the system, it is necessary to configure the detectors by appropriately setting the configuration switch SW2 located in the detector (see Figure 1, 6).

Two setting possibilities are distinguished:

- / last detector – switch setting for detectors working in the star-shaped system or the last detector in the connection in the open alarm loop system,

intermediate detector – switch setting for detectors working in the system of a closed alarm loop and detectors working in the open alarm loop system except for the last detector.

Architecture	Detector location	Settings of the configuration switch SW2
Open bus system	Last detector	Position 2 (last)
	Intermediate detector	Position 1 (intermediate)
Closed bus system	Any	Position 1 (intermediate)
Star system	Any	Position 2 (last)

Table 6: Device configuration



Inappropriate switch SW2 setting causes the system to malfunction (indicating failure and lack of response to a signal from the following detectors).

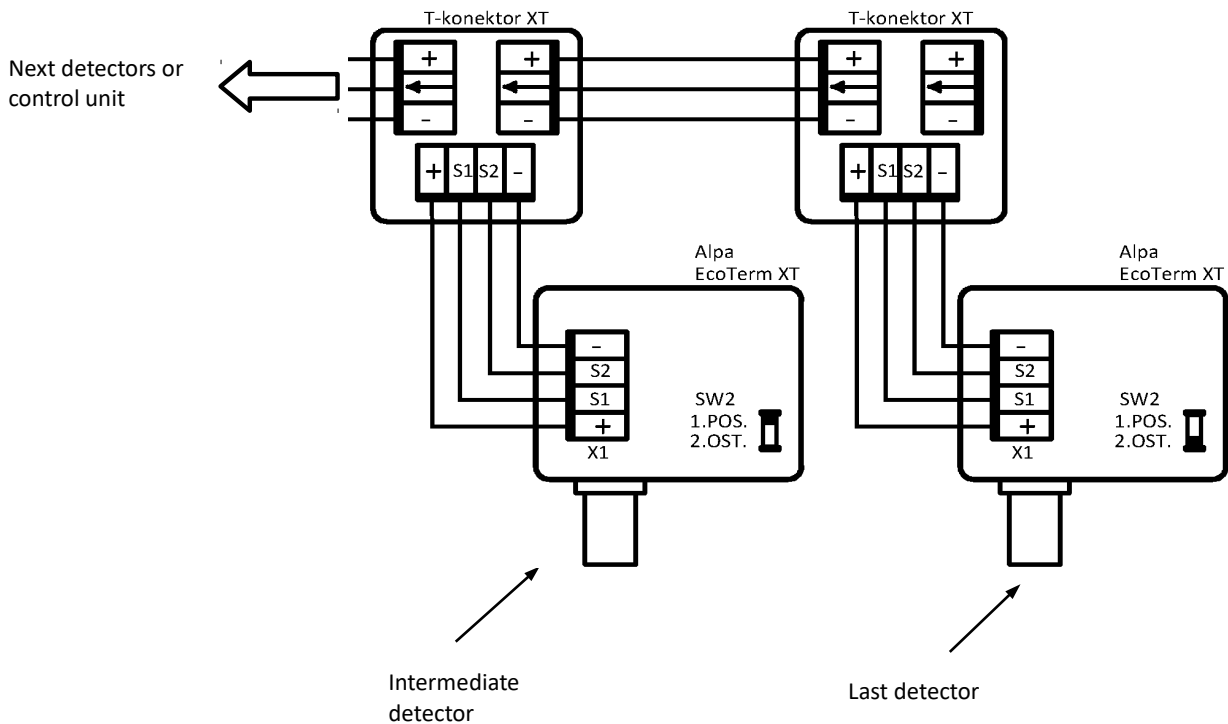

Figure 6: Settings of the configuration switch

7.2 Adjustment of the LED indicator intensity

Depending on a facility where the detectors are installed it is possible to adjust intensity of light indications emitted by the detector. Such an adjustment is carried out by means of the SW3 switch (see Figure 1).

The way how the detector status and operation mode is indicated in combination with the SW3 switch position is explained in Section 5.

In case of very high facilities it is recommended to move the switch for the light intensity setting to position 1 (LED – bright/strong).

When facilities are pretty low, for instance boiler rooms, the light intensity SW3 switch should be set to the position 2 (LED – dimmed/weak).

8 Diagnostics of electrical connections – searching for connection errors

In the case when the detector signals problems with connections (see section 5) the reasons of failure should be sought using the guidance contained in the table 7.

Indicator	Additional conditions	Possible cause of the problem
Indications according to the sequence provided in Table 3 (status of the interconnections check – failure)	The detector works as an intermediate one	Damaged XT T-connector, another detector connected to the BUS or inappropriate connection in the places indicated in the figure: Possible improper connection
	The detector works as the last one	Incorrect setting of the configuration switch (see section 7.1)
	The detector works as the last one	Incorrect setting of the configuration switch (see section 7.1)

Table 7: Reasons for failure signalling

9 Life cycle

9.1 Transport

The device should be transported in such a manner as new devices of this type. If the original box, extrusion or other protective elements (e.g. plugs) are not available, you must manually protect the device against shock, vibration and moisture using other equivalent methods.

Transport should take place in environmental conditions described in table 8.

9.2 Set-up

9.2.1 Location of detectors

The location of detectors should be determined by the designer of the system, taking into consideration the following principles:

- methane detectors should be installed less than 30 cm below the topmost point of the facility roof. Methane is lighter than air and tends to migrate upwards,

- gas detectors should be installed at locations where accumulation of gases is the most probable due to structural properties of the facility (e.g. any part of the facility is separated from the remaining space by means of structural components),
- the detectors should not be exposed to the direct impact of water or other chemical substances (e.g. cleaning agents during the facility cleaning), direct impact of sunlight, rain, water,
- the detector should be protected against damaging mechanical exposures,
- the detector location should enable conducting checks and the sensor adjustments, as well as its replacement or disconnection.

9.2.2 Installation

Electrical installation of the detectors may only be performed by persons having appropriate qualifications or acting in agreement or under the supervision of the manufacturer. The electrical installation should be performed in accordance with the design.

- The electrical installation of the detectors should be performed in accordance with the general principles of performing measurement and control systems³. Cables should be installed in a way protecting them from damage. Installation in cable ducts is required.



All activities related to the connection of the detectors and other components of the system must be made while the power supply to the control unit is switched off. Although the power supply to the gas detection system is switched off, there is a possibility that the source of dangerous voltage may be another system (e.g. a ventilation system using pin outputs).

- Or making connections, it is possible to use three-wire cables e.g. of the YTKSY, OMY, LiYY type (bus). For connecting the EcoWent XT detector, it is necessary to apply a four-wire conductor. The selection of a specific cable type depends on the designer and should take into account the conditions in the place in which the gas detection system operates. The maximum lengths of the wires connecting the detector with the control unit for a given cross-section of cable wire are given in Appendix [3].
- When selecting the cable, it is necessary to pay attention to voltage drops on the lines.



The power line should be designed in such a way that, at the lowest expected voltage of the line power supply, the voltage "seen" on the detector terminals does not drop below the permissible value (see Section 10).

- The spring clips of the terminal strip are released by pressing the button with a screwdriver.
- The detector should be mounted with the use of $\varnothing 6$ rawl bolts or M5 screws using the mounting holes accessible after the housing is open, so that the gas inlet is directed downwards. The housing dimensions, mounting hole spacing and the arrangement of the elements are shown in the Figure 1. To make the holes it is recommended to use drilling template enclosed in the packaging of the unit.

If the connection was made with the use of multi-wire cables (commonly known as a "cord"), the ends of these connectors should be ended with clamp sleeves.

3 Control and measurement instruments.

If there is a need to connect two conductors in one terminal of the device, the only allowable option is to connect them in a common clamping sleeve (details are provided in Table 8).



It is unacceptable to combine in one connector two wires which are not pinched in one cable lug.



Do not place the cable reserve in the device. Bare wires or wires surplus may create a danger of electric shock or equipment damage.



Do not leave disconnected cables inside the device.



Incorrect cable routing can lead to reducing the device's immunity from electromagnetic interference.

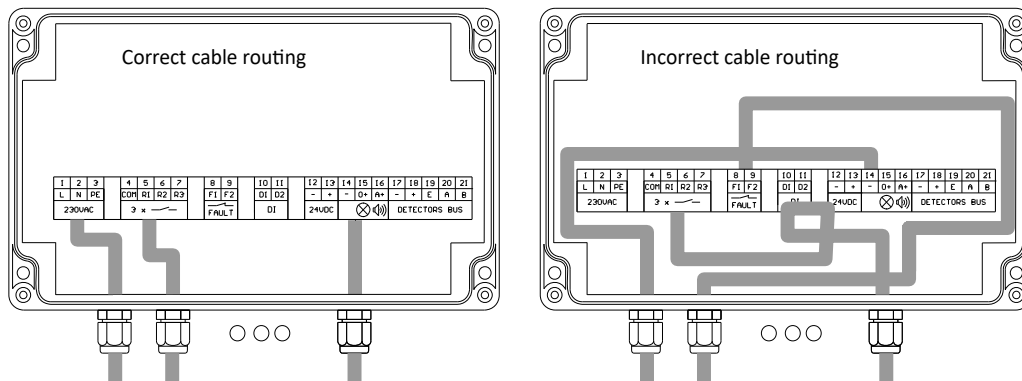

Figure 7: Example connection of cables to the device

9.2.2.1 Star system

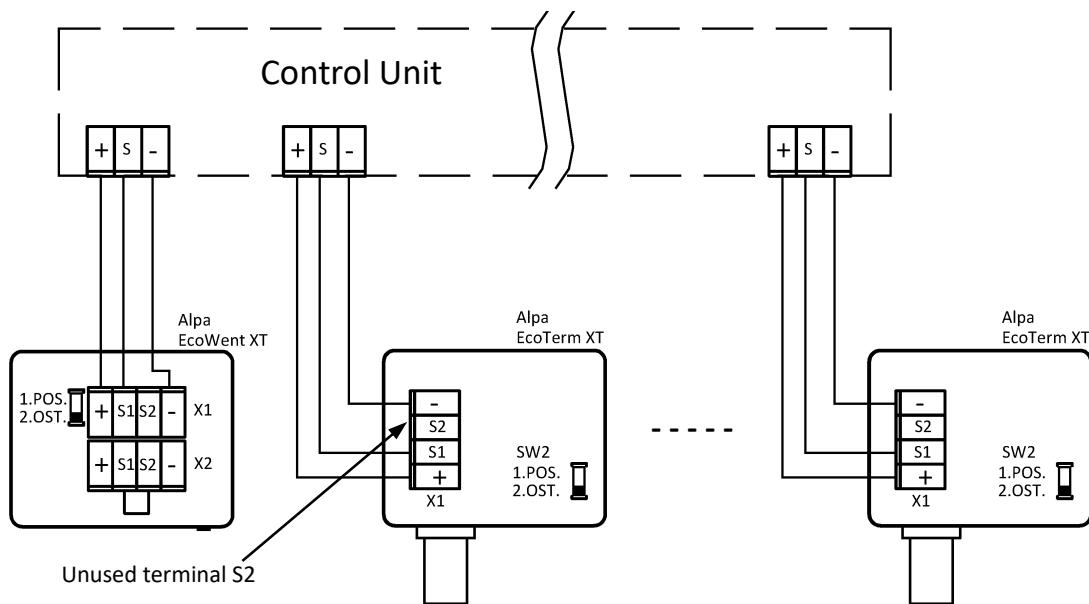

Figure 8: Connection into the star system



The configuration switch is always set in position 2 (last detector). For details, see Section 7.

- / Distribute connection cables in the facility, leaving appropriate reserve for connecting the detectors.
- / Install and provide power to the control unit. After the power supply is switched on, the state of "FAILURE" should be shown due to the lack of connected detectors. Turn off power to the control unit.
- / Mechanically fastened detectors on the object.
- / Connect the output of the first detector to the cable going into the control unit. The configuration switch in the detector should be in position 2 (last detector) – see Figure 8.
- / Connect cables leading from each specific detector to a relevant channel of the control unit. Upon powering up the control unit should indicate the 'OPERATION' ('PRACA') mode and the indicator LED on the detector shall blink during one minute (according to the sequence presented in Table 4 for the heating operation). After expiration of the heating time the LED should be permanently on or blink with green light.
- / If the control unit shows the "FAILURE" status – check and eliminate the possible connection errors.
- / If the control unit shows the state of "WORK" – perform the test of the detector operation. For this purpose, force "ALARM" by pressing the "TEST" button in the detector. The control unit should indicate "ALARM."
- / Turn off the power supply.
- / Repeat the installation steps for further detectors.

- Turn on the power supply when connecting all the detectors to the control unit. "WORK" should be indicated on all the channels of the control unit. Measure the power supply voltage on the sensor furthest from the control unit while pressing "TEST". It should not be less than 10 V.

9.2.2.2 Open alarm loop

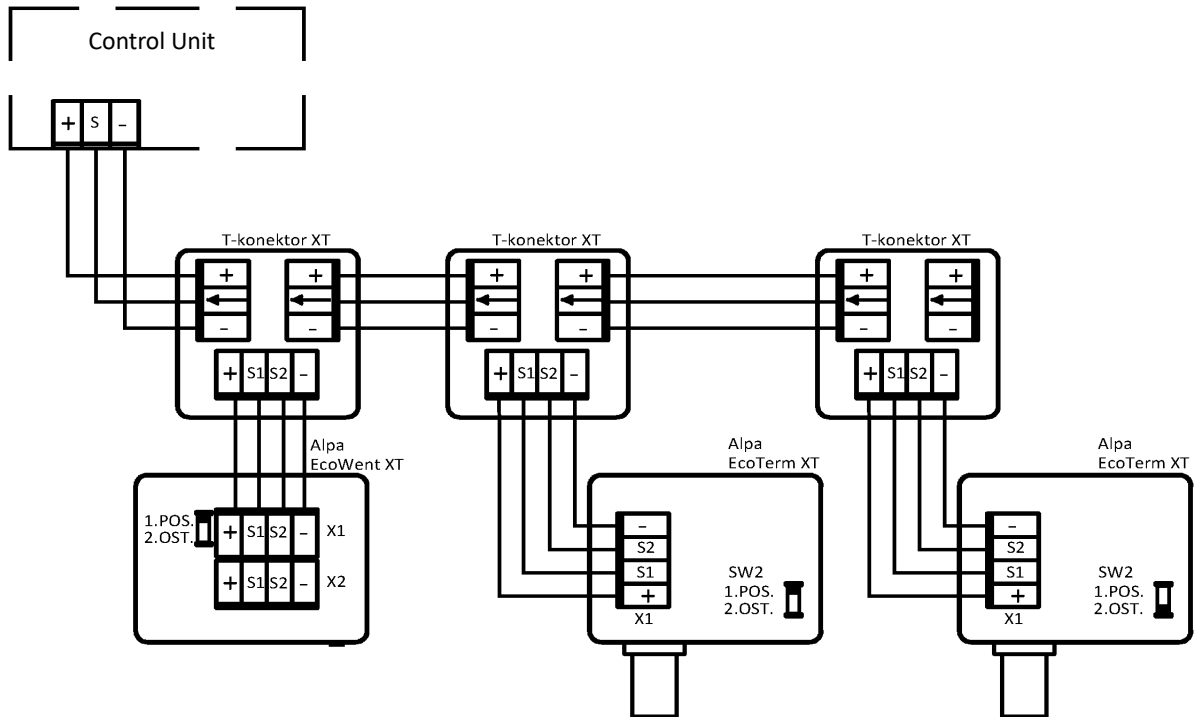

Figure 9: Open bus system



Connect all detectors with due care and pay particular attention to the configuration switch position for either a transient or a terminal detector. See details in Section 7.

- Route the main cable within the facility.
- Install and provide power to the control unit. After the power supply is switched on, the state of "FAILURE" should be shown due to the lack of connected detectors. Turn off power to the control unit.
- Mechanically fasten the detectors and the T-connectors on the facility. Connect the detectors with T-connectors.
- Connect the output of the first T-connector to the bus. Set the configuration switch in the detector to 2 (working as the last detector).
- After the power supply is switched on, the control unit should show the state of "WORK", and the controls on the sensor will blink subsequently for about 1 minute (stabilization of the sensor). After this time, the "OK" indicator will light up.
- If the control unit shows the "FAILURE" status – check and eliminate the possible connection errors.

- ✦ If the control unit displays the status of "OPERATION" – the configuration switch in the detector should be set to position 1 (working as an intermediate detector). The X1 indicator is lit in the detector, and the control unit should signal the failure of the detector (no detector at the end of the loop).
- ✦ Turn off the power supply.
- ✦ Repeat these steps for the next T-connectors and detectors.
- ✦ In the detectors, set the configuration switch in position 1. In the last detector, set the configuration switch in position 2 (see Figure 6). The control unit should show the state of "OPERATION" for the whole bus.
- ✦ Perform the test of the entire assembled bus. For this purpose, force the alarm on the last detector by pressing the "TEST" button in the detector. After a period of time dependent on the number of sensors (approx. 5-30 seconds), the control unit should signal "ALARM."
- ✦ With the pressed "TEST" button, measure the power supply voltage on the last detector. It should not be less than 10 V. If it is lower, it is recommended to use a higher power supply voltage or use a connection into a closed alarm loop.

9.2.2.3 Closed alarm loop

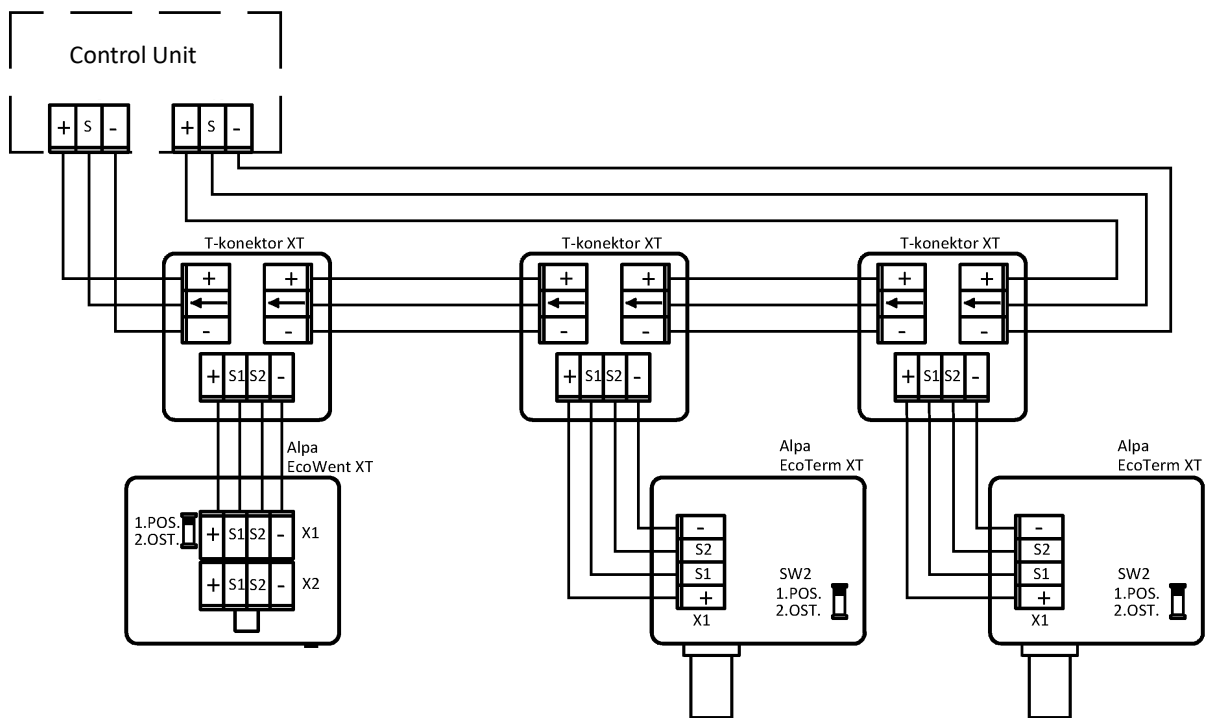

Figure 10: Closed alarm loop

This solution differs from the previous one only by the following details:

- ✦ configuration switches for all detectors incorporated into the loop (ring) are set to Position 1 (the control unit is considered as the terminal device) – see Figure 6,
- ✦ output of the last T-connector is linked to the input of the control unit.

9.3 Start-up

9.3.1 Handover inspection

After performing the power supply and signal installation of the detectors, it is necessary to check and start the installation. Checking is based on further addition of detectors (or their simulator – see below) to the installation and checking the reaction of the control unit.

9.3.2 Checking

The verification of the correctness of operation of the installation is based on:

- ✓ checking whether the control unit shows the status of "OPERATION" without the activation of the sensors with gas,
- ✓ activating the first detector with gas and checking the reaction of the control unit (it should display "WARNING" or "ALARM" – depending on the concentration of the fed gas),
- ✓ stimulation of the last detector with gas with checking of the control unit response as well as the response of all transient detectors (depending of concentration of the test gas they should activate their LED indicators according to the sequence provided in Table 4, respectively for exceeding of warning 1, warning 2 or alarm thresholds),
- ✓ random activation of selected intermediate detectors,
- ✓ random disconnection of the detectors and checking the reaction of the control unit – it should display the status of "FAILURE".

More information in Section 9.4.

9.3.3 Start-up of the system

After performing the electrical connection and handing it over to operation, the installation is ready to work. After performing the electrical installation, it is possible to conduct start-up and verification of the system in accordance with the procedure below:

- ✓ check the correctness of the electrical connections and the setting of the configuration switch,
- ✓ power the system up. All detectors should start the heating procedure, which is indicated by periodical blinking of the indicator LED (see Table 4). During the heating procedure all the control unit channels that are used by detectors should report the active operation. After about 1 minute all detectors and the control unit should report normal operation (provided that ambient air is free of any agent that may trigger activation of any detector),
- ✓ launch the test of the detector operation by pressing and holding the "TEST" button located inside the detector (see Figure 1) until the control unit signals "ALARM". Pressing the "TEST" button should cause the "ALARM" on the checked detector and control unit,
- ✓ with pressed "TEST" button (all detectors show the status of "ALARM") conduct the measurement of voltage on the most remote detector. The voltage cannot be lower than the minimum voltage of power supply to the detector (see Table 8). A too low value indicates an inappropriate selection of the conductor cross-section or too low voltage of the power supply to the system,
- ✓ it is recommended to conduct the reaction of the detectors with a span gas,
- ✓ the test of operation should be conducted for each detector,
- ✓ if the system does not work properly, it is necessary to check the correctness of connections or contact the manufacturer,

- the condition for admitting the system to use is conducting all the inspection operations with a positive result.

9.4 Periodical operations

During the operation of the gasometric system, it is necessary to be aware of the fact that the detectors – and most of all the sensors – are components susceptible to aging and environmental impacts. Therefore, the maintenance process must be performed systematically.

These operations may be conducted by trained services only, in accordance with the art, general safety principles and special installation conditions.

The periodic operations include:

- periodic inspections / calibration of detectors,
- replacement of consumables,
- periodical inspection.

9.4.1 Periodic inspection / calibration

The gas sensor incorporated into the detector subjects to ageing and environmental impacts, therefore worsening of its sensitivity in pace with time passing is a normal phenomenon.

To compensate that effect it is necessary to carry out maintenance services for detectors and their calibration under regular schedule (calibration frequency is specified in the Calibration Certificate – see Table 8). These services should be carried out for the Alpa EcoTerm XT Gas Detectors by a competent service company authorized by the manufacturer. The calibration can be carried out in several ways:

- detectors can be removed from the system and sent to the manufacturer for calibration,
- only MiniPel measuring heads can be taken out from Alpa EcoTerm XT Gas Detectors after opening of the device housing (see Figure 1) and sent to the manufacturer for calibration. Remember to mandatory power the gas detector off prior to disassembling.,
- refer to a service company authorized by the manufacturer to carry out the calibration process on site.

All expenses related to calibration (p&p, calibration itself and travelling expenses of calibration engineers) shall be borne by users.

9.4.2 Replacement of consumables

Details of the lifetime of consumables can be found in Table 9.

9.4.2.1 Replacement of the MiniPel Measuring Head

Metrological parameters or gas sensors subject to normal deterioration over operation time of gas detectors. Consequences of that phenomenon can be compensated by scheduled, regular adjustment of detector indications until the critical condition of the sensor is achieved and it must be replaced with a new one.

However, it is impossible to replace the sensor alone. The replaceable component is the entire measuring head – see Table 9.

To replace the head proceed in the following way:

- switch off the power voltage for the detector,
- undo the locking screw (see Figure 1),
- disconnect the head from its plug-in socket and connect a new head,

- fasten the locking screw,
- switch on the power voltage for the detector.

9.4.3 Periodical inspections

It is recommended to conduct periodical inspections every 12 months. Within the scope of a periodical inspections, it is necessary to conduct the visual inspection of the external installations and system devices, as well as to conduct the detector operation test:

- press and hold the "TEST" button on the inside of the detector until the control unit signals "ALARM". Pressing the "TEST" button should cause the "ALARM" on the checked detector and control unit,
- repeat the operation for all detectors.



To supply the test gas in a correct manner use a calibration kit and a reference gas, i.e. methane with concentration from 30% to 40% of LEL (see Section 12).



Do never test the detector by yourself by stimulating it with gas of unknown composition or concentration, i.e. from a gas lighter. Such an attempt may lead to damage of the gas sensor and /or de-calibration of the gas detector.

9.4.4 Maintenance

The only manner of cleaning the device is to wipe it with a damp soft cloth. Agents containing solvents, petrol or alcohols cannot be used to clean the detector.

9.5 Utilization



This symbol on a product or on its packaging indicates that the product must not be disposed of with other household waste. Instead, it is the user's responsibility to ensure disposal of waste equipment by handing it over to a designated collection point for the recycling of waste electrical and electronic equipment. The proper recycling of your waste equipment at the time of disposal will help to conserve natural resources and ensure that it is recycled in a manner that protects human health and the environment. Information about relevant designated collection points can be obtained from the Local Authority, waste disposal companies and in the place of purchase. The equipment can also be returned to the manufacturer.

10 Technical specification

Power supply • V_{CC} • I_{CC}	10 – 42 V \overline{DC} 160 mA	
Environment • Ambient temperatures • Humidity • Pressure	In-operation	Storage
	-20 – 50 °C 10 – 90% long term 0 – 99% short term 1013 ± 10% hPa	-20 – 50°C 20 – 80% long term
Detected substance	Methane (CH ₄)	
Measuring range	0 – 50% LEL	
Standard configuration • warning 1 • warning 2 • alarm	10% LEL 15% LEL 20% LEL	
IP	IP 43	
Digital input parameters • R_{IN}	200 Ω	
Analogue output parameters • R_{LOAD_MAX}	200 Ω	
The output signal according to the operating status of the detector: • failure • operation • warning 1 • warning 2 • alarm	<0.1 mA 4 mA 9 mA 11 mA 15 mA	
Integrated signalling equipment (optical)	LED control	
Protection class	III	
Dimensions	See Figure 1	
Cable glands (cable diameter range)	Cable glands pressed into installation pipes – pipe diameter 16 mm Multi-range cable glands – cable diameter 3.5 – 12 mm	
Acceptable cables	0.25 – 1.5 mm ² – solid wire 0.25 – 1 mm ² – stranded wire	
Enclosure material	ABS	
Weight	0.3 kg	
Mandatory periodic inspection	Once a year (valid calibration certificate)	
Lifetime of consumables	See Table 9, Section 11	
Mounting	4 openings for a screw with a diameter of 4 mm, for spacing see Figure 1	

Table 8: Technical specification

11 List of consumables

No.	Consumable item	Life time	Manufacturer	Product code
{1}	Measuring Head MiniPel	5 years	Atest Gaz	PWS-016-NG

Table 9: List of consumable parts

12 List of accessories

Product code	Description
PW-049-CB3	CB3 Service Cable
PW-064-WM1	Mounting Adapter WM1 (for wall mounting)
PW-064-WM2	Mounting Adapter WM2 (for ceiling mounting)
PW-092-B	Calibration kit
-	Standardized reference gas – methane CH ₄ 40% DGW

Table 10: List of accessories

13 Product marking

Product code	Device
PW-100-NG	Gas Detector Alpa EcoTerm XT

Table 11: Method of product's marking

14 Appendices



- [1] DEZG116-ENG – EC Declaration of Conformity – Alpa EcoTerm XT
- [2] PU-Z-054-ENG – Parameters of gas detectors with catalytic sensor
- [3] PU-Z-106-ENG – Maximum quantity of Alpa EcoTerm XT detectors by cable type
- [4] PU-Z-039-ENG – Classification of chemicals used at Atest Gaz

EU Declaration of Conformity

Atest Gaz A. M. Pachole sp. j. declares with full responsibility, that the product:

(Product description) Gas Detector	(Trade name) Alpa EcoTerm XT	(Type identifier or Product code) PW-100
--	--	--

complies with the following Directives and Standards:

-  in relation to Directive 2014/30/EU – on the harmonisation of the laws of the Member States relating to electromagnetic compatibility:
 - EN 50270:2015
-  in relation to directive 2011/65/EU – on the restriction of the use of certain hazardous substances in electrical and electronic equipment:
 - EN IEC 63000:2018

This declaration of conformity is issued under the sole responsibility of the manufacturer.

This EU Declaration of Conformity becomes not valid in case of product change or rebuild without manufacturer's permission.

Gliwice, 26.04.2022



(Name and Signature)

Managing Director
Aleksander Pachole

Parameters of gas detectors with catalytic sensors

1 Detected substances

Detectors equipped with catalytic sensors are used for measuring and detecting the presence of gases and flammable gases in the range of up to 100% LEL.

2 Principle of operation

The catalytic sensor (figure 1) consists of two components: an active and a passive one, heated to a high temperature. They are both constructed of a very thin coiled platinum wire, however, the active element (figure 2) is additionally coated with a catalyst (e. g. palladium, platinum). A combustion reaction occurs on the active element. Heat is generated as a result, which causes an increase in the temperature of this element and a resultant change in its resistance. Whereas combustion is not possible on the passive element, therefore, its properties do not change under the influence of a combustible substance. This allows the passive element to compensate for the impact of ambient temperature. The same resistance change of both elements occurs when the ambient temperature changes. The passive and active elements are integrated in the Wheatstone bridge circuit, which ensures conversion of the change of resistance to voltage.

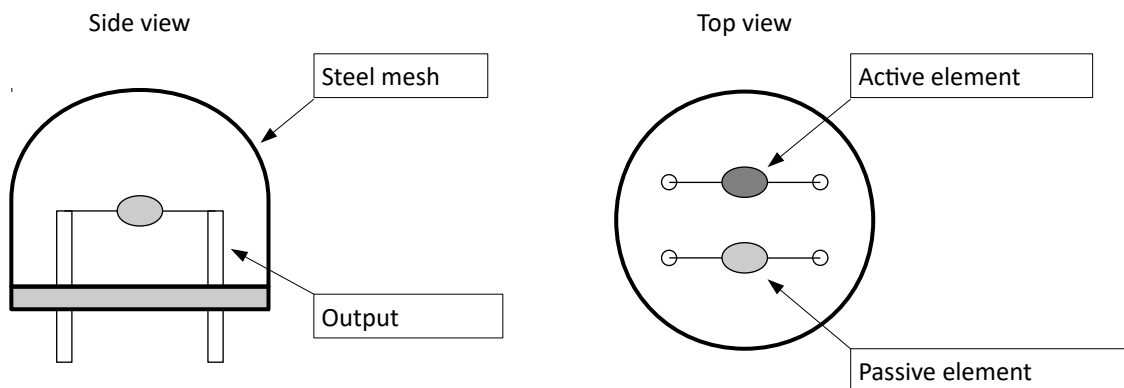

Figure 1: Sample view of catalytic sensor

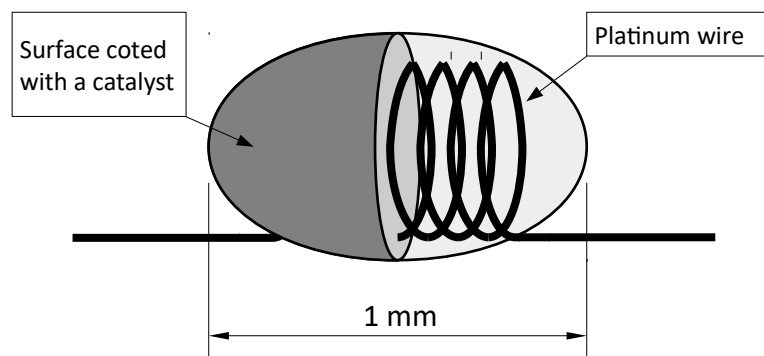

Figure 2: Active element construction

3 Impact of environmental conditions



Never exceed the rated operating parameters of the detector. These parameters can be found in the detector calibration certificate.



The detector must be used in accordance with the provisions in the User's Manual.

3.1 Composition of the controlled atmosphere

It is assumed that the standard composition of the atmosphere is a mixture of gases with the proportions indicated in table 1.

Ingredient	C [% vol]	C [ppm]
Nitrogen	78.084	780 840
Oxygen	20.946	209 460
Argon	0.934	9 340
Carbon dioxide	0.0360	360
Neon	0.00181	18.18
Helium	0.00052	5.24
Methane	0.00017	1.70
Krypton	0.00011	1.14
Hydrogen	0.00005	0.50
Xenon	0.000008	0.087

Table 1: Typical composition of atmospheric air

When gas concentrations in the atmosphere differ significantly from those indicated in the table 1, it is necessary to conduct the analysis of the impact of such a situation on the detector operation.



Catalytic sensor working properly at an oxygen concentration of about 21%.

3.1.1 Impact of the presence of a working gas or other reaction gas

Catalytic sensor isn't selective – it reacts (with different sensitivity) to most flammable substances appearing in its surroundings. Because of that it is necessary to consider their presence when the sensor is operating.

When using detectors with catalytic sensors, it is necessary to be aware that:

- long-term presence of significant concentrations results in faster sensor wear. Basically, catalytic sensors are used to detect the incident presence of combustible gases. They should not work in atmospheres in which flammable gases at concentrations greater than about 20% LEL occur in a continuous or prolonged manner, as it may lead to a rapid reduction of their sensitivity and the appearance of a zero drift,

- / concentrations over 100% LEL, even temporarily persistent ones, can lead to a physical wear of the sensor. For these reasons, detectors operating in places where such conditions may occur are / should be equipped with mechanisms to prevent the negative effects of high concentrations,
- / a very high concentration of combustible gas (well above 100% LEL) leads to a decrease in oxygen concentration – thereby lowering the sensor's indication. Volumetric concentrations close to 100% can result in a zero sensor response, as shown in the figure (example: a small room and a large amount of flammable gas released into the atmosphere). See section 3.1.2.

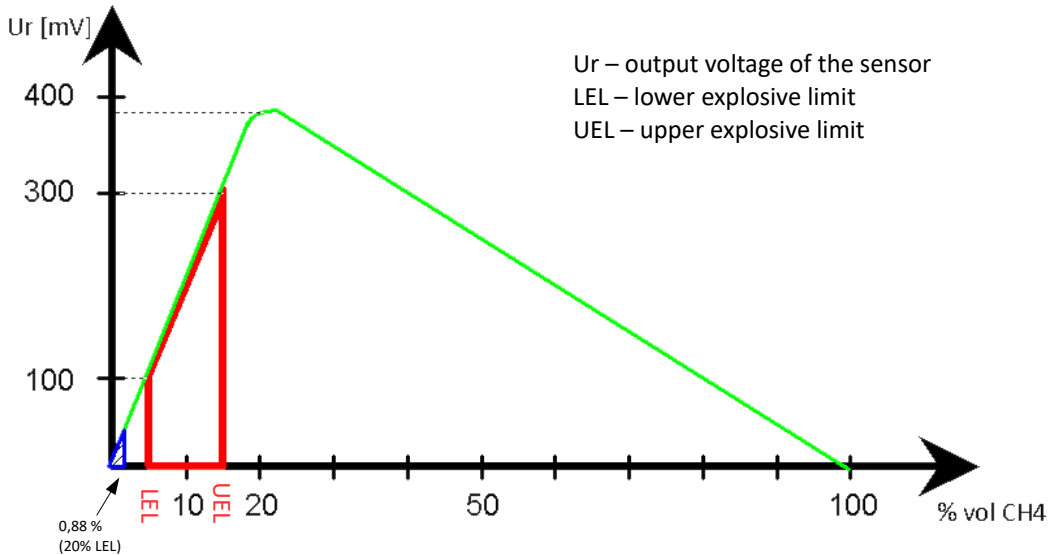

Figure 3: Sample characteristic of catalytic sensor

3.1.2 Effect of oxygen concentration value

Oxygen is required for a proper operation of the catalytic sensor. If the monitored atmosphere contains gas or gases that dilute or replace air (thereby reducing the oxygen concentration), for example, nitrogen or carbon dioxide, then the catalytic detector can give a low or even zero response.

A similar effect can occur when large amounts of reaction gas are released to the atmosphere (creating a concentration over the measurement range) – due to a too low amount of oxygen, the concentration indication of the detector will be lower than it actually is, and it may even be zero.

3.2 Influence of temperature

The temperature can have an influence on the sensor's characteristics. Within the scope of the detector's environmental parameters, its influence is compensated electronically.

3.3 Influence of pressure



Within the environmental parameters of the sensor, the influence of pressure on the measurement is negligible.

3.4 Influence of moisture

Within the environmental parameters of the sensor the influence of moisture on the measurement is negligible.



3.5 Influence of vibrations, impacts

Vibrations and impacts affect the detector's operation, as they may cause:

-  damage to delicate parts of the sensor (e. g. detector element, compensation element),
-  shift of the sensor's zero.

It should be ensured that the detector is not exposed to shock and vibration in excess of the amplitude of vibrations amounting to 0.15 mm of the frequencies of over 10 Hz. Under no circumstances should the peak acceleration exceed the value of 19.6 m/s².

3.6 Influence of physicochemical phenomena



-  In the case of chemical compounds with high flash point (approx. 50°C and above) it is necessary to remember that in typical environmental conditions (ambient temperature below 40°C), it is unlikely that they will be able to produce atmospheres close to 100% LEL. Particularly in the case of ambient temperatures below 0°C it may occur that achieving measurable concentrations by the catalytic sensor (of 10% LEL) is impossible. Another measurement method is required in this case.
-  High concentrations of inserting gases (e. g. argon, helium) can change the thermal equilibrium of the sensor, resulting in the apparent reading of the presence of a combustible substance.

4 Factors shortening the lifetime of the sensor



4.1 Poison and inhibitors

For every reaction with the presence of a catalyst that cause permanent (poisons) or temporary deceleration (inhibitors) of this reaction, which results in reduced sensor sensitivity – in particular the lack of reaction to a combustible substance.

For catalytic sensors, on the active element side, we distinguish the following poisons:

-  silicons (organosilicone compounds) – e. g. PDMS (polydimethylsiloxane), HDMS (hexamethyldisiloxane), sealants, adhesives, raising agents, specific oils and lubricants, some medical supplies,
-  organometallic compounds – e. g. Grignard compounds, lead tetrachloride (leaded petrol, certain aviation fuels),
-  organophosphorus compounds – e. g. in herbicides, insecticides, phosphoric esters in fire-proof hydraulic fluid,

and inhibitors:

-  sulfur compounds – e. g. hydrogen sulfide, mercaptans, carbon disulphide, sulfur dioxide,
-  halogen compounds – e. g. methyl chloride, some freons (among others R134a), vinyl chloride,
-  olefins – e. g. styrene, propylene, acrylonitrile.

Acetylene is a poison for the passive element of the catalytic sensor.

Maximum quantity of Alpa EcoTerm XT detectors by cable type

1 Open loop configuration

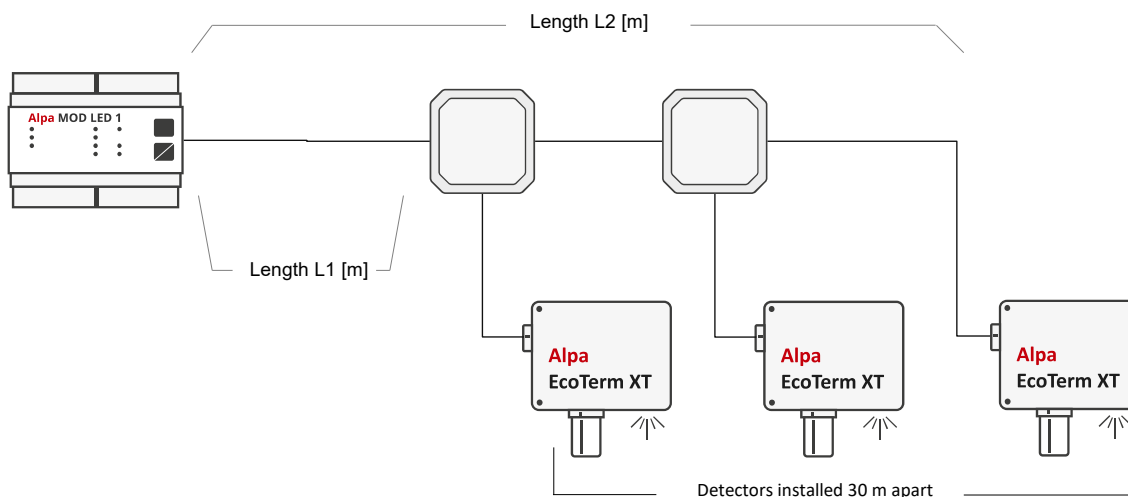

L1 – distance T-connector of the first detector from the control unit
 L2 – distance T-connector of the last detector from the control unit

Figure 1: Open loop configuration

Cross-section of a single cable conductor [mm ²]	Alpa EcoTerm XT Gas Detector					
	System without backup battery supply (U _{IN} = 24 V)			System with backup battery supply (U _{IN(min)} = 20 V)		
	L1 [m]	L2 [m]	Quantity of detectors	L1 [m]	L2 [m]	Quantity of detectors
1	48	408	13	34	334	11
	81	411	12	67	337	10
	115	415	11	102	342	9
	153	423	10	141	351	8
	196	436	9	187	367	7
1,5	47	497	16	49	409	13
	79	499	15	82	412	12
	113	503	14	117	417	11
	148	508	13	155	425	10
	187	517	12	198	438	9
	229	529	11	248	458	8
2,5	39	669	22	42	552	18
	72	672	21	74	554	17
	104	674	20	108	557	16
	137	677	19	142	562	15
	172	682	18	179	569	14

Table 1: Maximum quantity of Alpa EcoTerm XT detectors – open loop configuration

2 Closed loop configuration

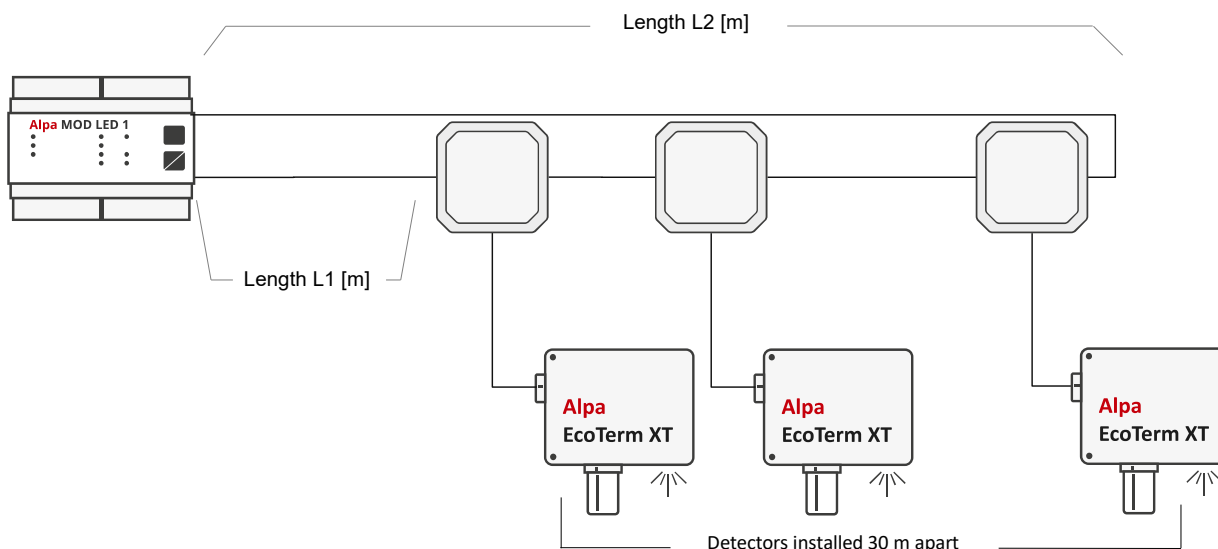

L1 – distance T-connector of the first detector from the control unit
 L2 – distance T-connector of the last detector from the control unit (also the length of loop return cable)

Figure 2: Closed loop configuration for Alpa EcoTerm XT detectors

Cross-section of a single cable conductor [mm ²]	Alpa EcoTerm XT Gas Detector					
	System without backup battery supply (U _{IN} = 24 V)			System with backup battery supply (U _{IN(min)} = 20 V)		
	L1 [m]	L2 [m]	Quantity of detectors	L1 [m]	L2 [m]	Quantity of detectors
1	61	541	17	58	448	14
	93	543	16	90	450	13
	128	548	15	127	457	12
	166	556	14	167	467	11
	207	567	13	213	483	10
1,5	56	656	21	33	543	18
	88	658	20	64	544	17
	122	662	19	97	547	16
	157	697	18	132	552	15
	195	705	17	170	560	14
2,5	41	881	29	40	730	24
	72	882	28	72	732	23
	104	884	27	104	734	22
	139	889	26	138	738	21
	171	891	25	174	744	20
	207	897	24	211	751	19

Table 4: Maximum quantity Alpa EcoTerm XT detectors – closed loop configuration

3 Star configuration

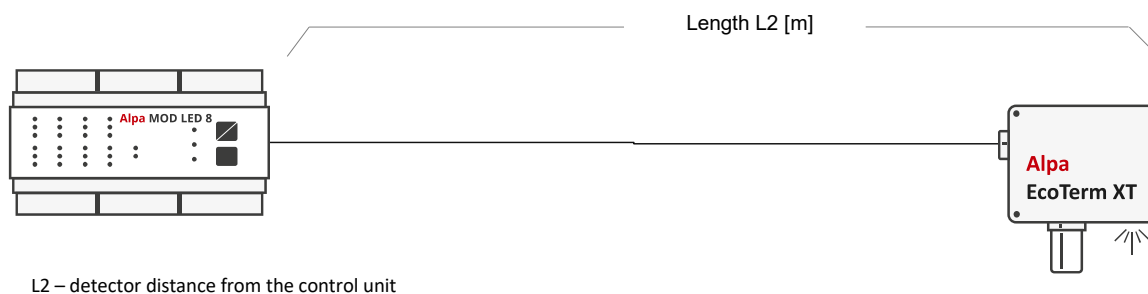

L2 – detector distance from the control unit

Figure 3: Star configuration

Cross-section of a single cable conductor [mm ²]	System with backup battery supply ($U_{IN(min)} = 20\text{ V}$)	
	One Alpa EcoTerm XT Gas Detector at the end of the line	
	L2 [m]	
1	1400	
1,5	1400	
2,5	1400	

Table 7: Maximum length of cables – star configuration

Classification of chemicals used at Atest-Gaz

Because of the need to present a **consistent and high level of maintenance services**, to ensure **the safety of the calibration process** and to **create a basis for a rational calculation of the costs** of this process, Atest-Gaz developed the "Classification of Chemical Substances" described below.

The classification determines the complexity of the calibration process of a particular detector type, consider two criteria:

- ✍ stability of the calibration mixture (criterion **A**):
 - ease of generate and its stability,
 - ergonomic complexity of operations,
 - required experience and knowledge of the employee performing the calibration,
 - required equipment,
 - environmental requirements for the process (e.g. weather conditions).
- ✍ safety / potential hazard generated by the mixture (criterion **B**).

These both criteria have an impact on the final cost of the calibration services and level of competence required from the employee conducting the calibration.

This classification is applied both by Atest-Gaz and the entities cooperating with it – distributors, authorized service providers and users of the systems.

In the case of calibration with the "crossover" substances, the classification is made in accordance with the substance category that is applied (e.g. for the detector with a PID sensor this substance is isobutylene, i.e. BO A0).

The detector are classified on the stage of offer.

On the next page we present tables showing the above relationships.

Category	Description	Terms of facility calibration
A0	Cylinder gases, stable environment	No precipitations, and no strong winds, and temperature over -10°C^1 . In other cases, calibration at a location that meets the above conditions (necessary to remove the detectors).
A1	Cylinder gases, unstable environment or absorption by the moisture	No precipitations, and no strong winds, and temperature over $+10^{\circ}\text{C}^1$, and relative humidity under 70%. In other cases, calibration at a location that meets the above conditions (necessary to remove the detectors).
A2	Gases not available in cylinders can be generated at the relevant facilities	like A1 In other cases, calibration at a location that meets the above conditions (necessary to remove the detectors).
A3	Laboratory calibration	Facility calibration impossible, laboratory calibration only, probably at the manufacturer's. This group also includes conditions resulting from other reasons, e.g. the need for temperature compensation, non-linearity of the sensor, the need for calculation, the use of special tools, etc.

Table 1. Classification of chemicals used at Atest-Gaz. Criterion A: mixture stability

Category	Description	Classification criteria
B0	Safe substances	concentration of flammable components $< 60\% \text{ LEL}$, and concentration of toxic components $\leq \text{NDSch}^2$, and oxygen concentration $< 25\% \text{ vol}$, and tank $< 3 \text{ dm}^3$ (water capacity) and $p \leq 70 \text{ atm}$, or specified liquid chemical compounds, e.g.: glycerol, 1,2-propanediol.
B1	Low-risk substances	concentration of flammable components $< 60\% \text{ LEL}$, and concentration of toxic components $\leq \text{NDSch}^2$, and oxygen concentration $< 25\% \text{ vol}$, and tank $> 3 \text{ dm}^3$ (water capacity) or $p > 70 \text{ atm}$, or toxic gases with the concentration of $\text{STEL} \div 15 \times \text{NDSch}$, or specified liquid chemical compounds, e.g.: petrol, acetone, 1-methoxy-2-propanol.
B2	High-risk substances	inert gases having an oxygen concentration $> 25\% \text{ vol}$, or flammable gases with a concentration $> 60\% \text{ LEL}$, or specified liquid chemical compounds, e.g.: styrene, methanol, xylene, toluene, methyl methacrylate.
B3	Extremely dangerous or extremely flammable substances	toxic gases with the concentration of $> 15 \times \text{NDSch}^2$, or specified liquid chemical compounds, e.g.: benzene, formaldehyde, formic acid, epichlorohydrin.

Table 2. Classification of chemicals used at Atest-Gaz. Criterion B: OHS

- 1 Is allowed to perform calibrations at lower temperatures, if they meet the conditions of operation of the detector, e.g. ammonia refrigeration units.
- 2 In the absence of determined NDSch it is necessary to adopt $2 \times \text{NDS}$ as a criterion.



Atest Gaz A. M. Pachole sp. j.
Spokojna 3, 44-109 Gliwice

tel.: +48 32 238 87 94
fax: +48 32 234 92 71
e-mail: contact@atestgaz.pl

For more details on our devices and other products and services offered by us, visit:

www.atestgaz.pl/en